

# CBCS SCHEME

USN

--	--	--	--	--	--	--	--	--	--

18ME53

## Fifth Semester B.E. Degree Examination, June/July 2023 Dynamics of Machines

Time: 3 hrs.

Max. Marks: 100

Note: Answer any FIVE full questions, choosing ONE full question from each module.

### Module-1

- 1 a. Explain the following terms with neat diagrams:
- Equilibrium of three force system
  - Equilibrium of two force and a torque
- (06 Marks)
- b. A four-link mechanism with the following dimensions is acted upon by a force 100 N  $\angle 150^\circ$  N on the link DC [Fig.Q1(b)]. AD = 500 mm, AB = 400 mm, BC = 900 mm and DC = 750 mm, DE = 350 mm. Determine the input torque T on the link AB for the static equilibrium of the mechanism for the given configuration.

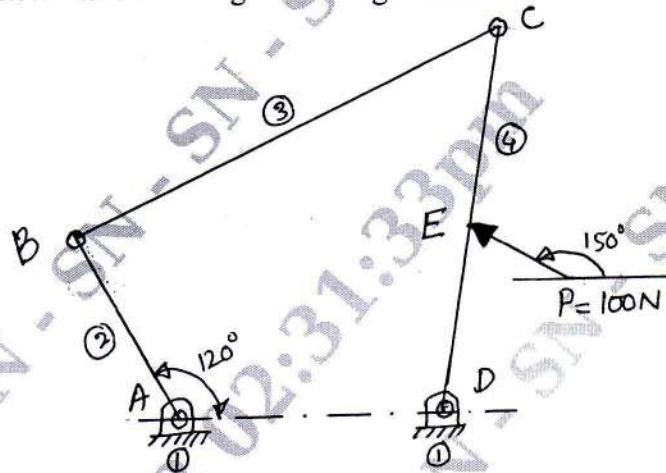

Fig.Q1(b)

(14 Marks)

OR

- 2 a. State and explain D'Alembert's principle. (06 Marks)
- b. The following data relate to a horizontal reciprocating engine:
- Mass of reciprocating parts = 120 kg
  - Crank length = 90 mm
  - Engine speed = 900 rpm
  - Connecting rod:
    - Mass = 90 kg
    - Length between centers = 450 mm
    - Distance of center of mass from big end center = 180 mm
    - Radius of gyration about an axis through center of mass = 150 mm
- Find the magnitude and the direction of the inertia torque on the crankshaft when the crank has turned  $30^\circ$  from inner dead center. (14 Marks)

### Module-2

- 3 a. What do you mean by static balancing and dynamic balancing? Explain. (06 Marks)

- b. Four masses A, B, C and D are completely balanced. Masses C and D make angles of  $90^\circ$  and  $195^\circ$  respectively with that of mass B in the counter clockwise direction. The rotating masses have the following properties:

Mass of B = 25 kg                      Radius of mass A at A plane = 150 mm

Mass of C = 40 kg                      Radius of mass B = 200 mm

Mass of D = 35 kg                      Radius of mass D = 180 mm

Planes B and C are 250 mm apart. Determine the :

- (i) Mass A and its angular position with that of mass B  
 (ii) Positions of all the planes relative to plane of mass A.

(14 Marks)

OR

- 4 a. Explain complete balancing of reciprocating parts. (05 Marks)  
 b. The cranks of a four-cylinder marine oil engine. Cranks are arranged at angular intervals of  $90^\circ$ . The engine speed is 70 rpm, and the reciprocating mass per cylinder is 800 kg. The inner cranks are 1 m apart and the outer are 2.6 m apart. The inner cranks are symmetrically arranged between the outer cranks. Each crank is 400 mm long.  
 Determine the firing order of the cylinders for the best balance of reciprocating masses and also the magnitude of the unbalanced primary couple for that arrangement. (15 Marks)

Module-3

- 5 a. Derive the expression for equilibrium speed of porter governor. (08 Marks)  
 b. Each arm of a porter governor is 250 mm long. The upper arms are pivoted to links of 40 mm from the axis of rotation. The lower arms are pivoted to links of 50 mm from the axis of rotation. Each ball has a mass of 5 kg and the central mass is 50 kg. The force of friction on the sleeve of the mechanism is 40 N. Determine the range of speed of the governor for extreme radii of rotation of 125 mm and 150 mm respectively. (12 Marks)

OR

- 6 a. Explain gyroscopic couple effect on steering, pitching and rolling with respect to naval ship. (06 Marks)  
 b. What is angle of heel? Explain its importance. (02 Marks)  
 c. An aeroplane flying at 300 kmph turns towards the left and completes a quarter circle of 60 m radius. The mass of rotary engine and propeller of the plane is 450 kg with a radius of gyration of 320 mm. The engine speed is 2000 rpm clockwise when viewed from the rear. Determine the gyroscopic couple on the aircraft and state its effect.  
 In what way is the effect changed when the (i) aeroplane turns towards right (ii) engine rotates clockwise when viewed from the front (nose end) and aeroplane turns left. (12 Marks)

Module-4

- 7 a. Explain energy method to find natural frequency of spring-mass-system. (06 Marks)  
 b. What is the effect of spring mass? Derive the expression for natural frequency of the system. (06 Marks)



- c. Determine the frequency of vibration of the system shown in Fig.Q7(c). Use the following data  $m = 10 \text{ kg}$ ,  $K_1 = 200 \text{ N/m}$ ,  $K_2 = 400 \text{ N/m}$ .

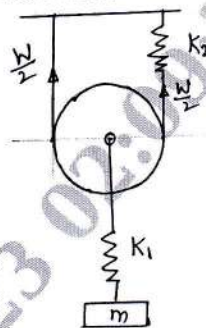

Fig.Q7(c)

(08 Marks)

OR

- 8 a. Setup the differential equation for a spring mass damper system and obtain complete solution for the under-damped condition. (10 Marks)
- b. Determine :
- Critical damping coefficient
  - Damping factor
  - Natural frequency of damped vibrations
  - Logarithmic decrement
  - Ratio of two consecutive amplitude of vibrating system which consists of mass of 30 kg, a spring of stiffness 1800 N/m and a damper. The damping provided is only 15% of the critical value. (10 Marks)

Module-5

- 9 a. Derive the expression for the maximum displacement for forced vibration of undamped single degree freedom system. (08 Marks)
- b. Explain vibration isolation. (02 Marks)
- c. A machine of total mass 18 kg is mounted on springs having stiffness  $K = 12000 \text{ N/cm}$ . A piston within the machine has a mass of 2 kg has a reciprocating motion with stroke 7.5 cm and speed 6000 rpm. Assuming the motion to be SHM. Determine:
- Amplitude of vibration
  - Transmissibility
  - Force transmitted to the ground to foundation.
- Take  $\xi = \text{damping ratio} = 0.2$ . (10 Marks)

OR

- 10 a. Define critical speed and explain its types. (05 Marks)
- b. A shaft supported freely at the ends has a mass of 120 kg placed 250 mm from one end. The shaft diameter is 40 mm. Determine the natural frequency of the transverse vibrations if the length of the shaft is 700 mm. Take  $E = 200 \text{ GN/m}^2$ . (05 Marks)
- c. The following data relate to a horizontal shaft held in long bearings.
- Length of the shaft = 1.2 m  
 Diameter of the shaft = 14 mm  
 Mass of rotor at mid point = 16 kg  
 Eccentricity of center of mass of rotor from center of rotor = 0.4 mm  
 $E = 200 \text{ GN/m}^2$   
 Permissible stress in the shaft material =  $70 \times 10^6 \text{ N/m}^2$   
 Determine the critical speed of the shaft and the range of speed over which it is unsafe to run the shaft. Neglect mass of the shaft. (10 Marks)

\*\*\*\*\*